

Maintenance

Spare Parts kits

1. Introduction

Maintenance must only be carried out by qualified personnel only using suitable tools and working methods. Before any maintenance steps are taken, make sure the power switch is in the off position and locked by a padlock. Make sure the propeller is at a complete standstill.

2. Clear dust

Inspect the fan at regular intervals and keep it clean. It is advised to perform periodic cleaning of safety mesh guards, motor and plastic bearings. Dust on the safety mesh guards causes extra power consumption; severe dust on the motor can cause overheating and subsequent motor failure. Do not use water for motor cleaning. Use compressed air only. Water spraying will cause rust inside the bearings and lead to their failure.



WARNING

All the components and spare parts **MUST** be stored in dry and clean environment.

3. Belt tensioning check up and replacement

Check V-belt tension at regular intervals, or after its replacement, the correct tension is obtained when maximum deflection (half-way from motor and central pulley) is about 15 mm, when pushed in by thumb.

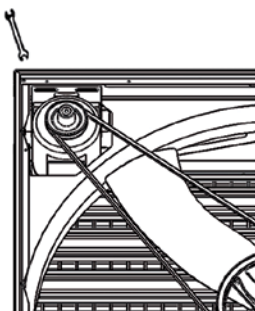

fig. 1

1. With the propeller at a complete standstill, open the safety mesh guard on the pulley/motor side.
2. Loosen motor slide fixing screws.
3. Tighten the V-belt by pushing the motor sideways.
4. Tighten the fixing screws adequately.
5. Fix the safety meshes guard to the fan housing.



WARNING

Tighten fan belt after the fan has been running for 3 days. Without adjusting the tension, transmission components can wear out early.



WARNING

Do not operate the fan with the safety protections removed and wait until the fan reaches a complete standstill.

Therefore, if for maintenance reasons the user damages or loses any component, this must be definitely ordered from the manufacturer as spare parts and it cannot just be replaced with other components, even similar, not supplied by the constructor itself. In this particular event the manufacturer refuses all responsibility on consequent damages caused to things and people and considers any kind of warranty lost.

4. Replacement of central pulley

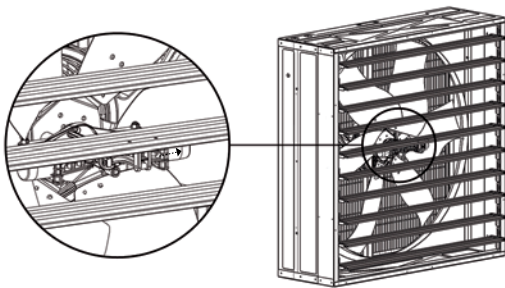

fig.2

1. Open shutter by hand and take away the pin, which connects central shutter blade to centrifugal system.

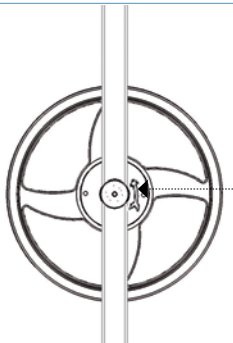

fig.3

2. Loosen motor to propeller V-belt from pulleys throat.
3. Unscrew the fixing nut.

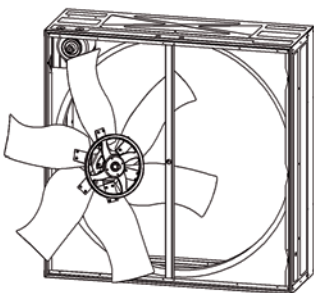

fig.4

4. Take out the pulley-propeller-centrifugal system assembly from fan frame.

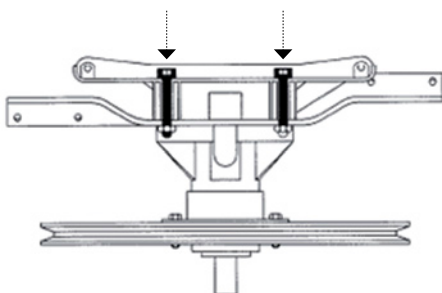

fig. 5

5. Remove centrifugal system by unscrewing central allen screws fixing it to propeller.
6. Disassemble the propeller from central pulley unscrewing the 4 hub fixing screws.
7. Assemble the new central pulley following the reverse procedure.

5. Replacement of shutter bearing assembly

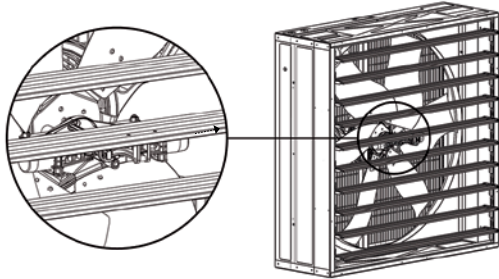

fig.6

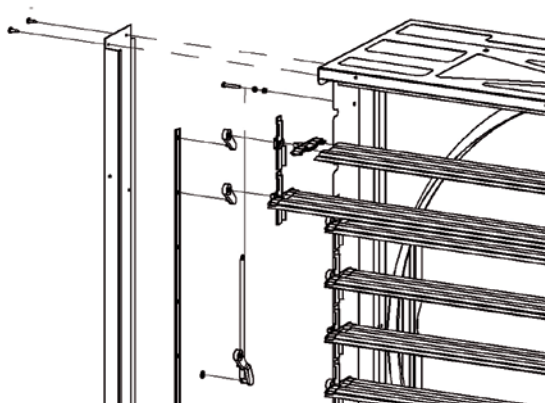

fig.7

1. Open shutter by hand and take away the pin, which connects central shutter blade to centrifugal system.
2. Remove the side cover plates (see n. 1) and break steel stop collars (see n.9) on central bearing assembly with pliers
3. Unthread two tie-rod with holes (see n.8) and unscrew bolts (see n.2) and nuts (see n.3) which fix shutter closing spring.
4. Pull off the shutter blades (see n.7) from their slot and unhook the shutter bearing assembly (see n.4,5,6).
5. Insert the new shutter bearing assembly.
6. Put back the shutter blades and fix the closing springs in their position.
7. Fit the cover side plates back (see n. 1).

Bearings are properly sized, with double sealed protection (2RS) and lubricated for life, therefore they do not require any additional lubrication.

6. Replacement of shutter opening device (centrifugal system)

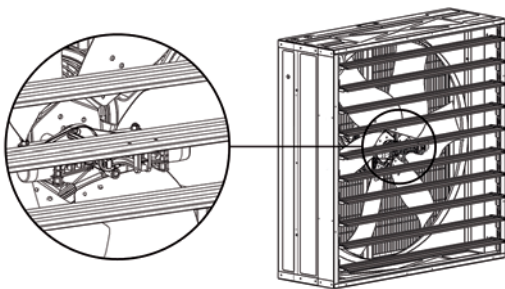

fig.8

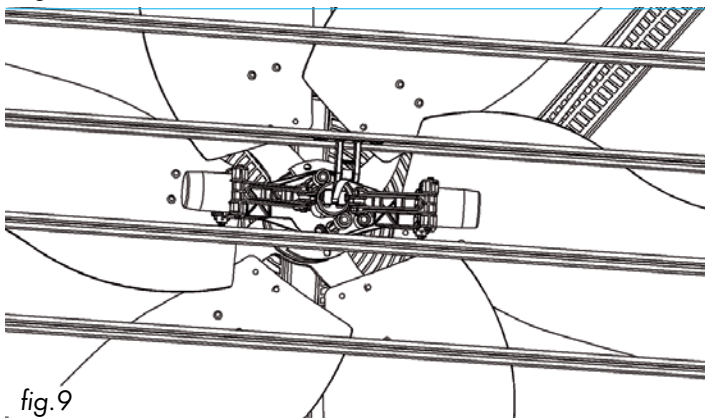

fig.9

1. Open shutter by hand and take away the pin, which connects central shutter blade to centrifugal system.
2. Unscrew the two M8 hexagonal socket head cap screws and pull out the whole centrifugal system through the shutter blades.
3. Do the reverse procedure to replace the shutter opening device and put back the pin, which connects central shutter blade to centrifugal system.